

Arbeitsunterlagen Jugendmöbel

Anlagen

Anlage A: Würfelmodule - Übersicht

Modulübersicht:

Modul R Würfelmodul als offenes Regal (Basismodul)

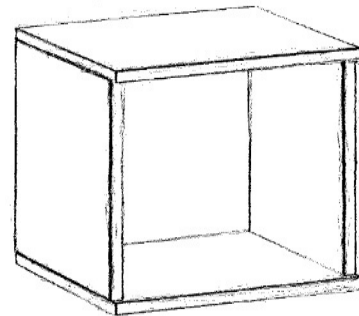
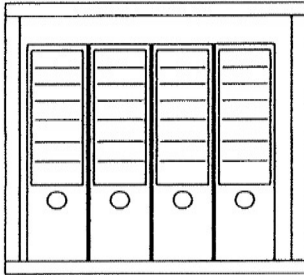

Modul T Würfelmodul mit Drehtür

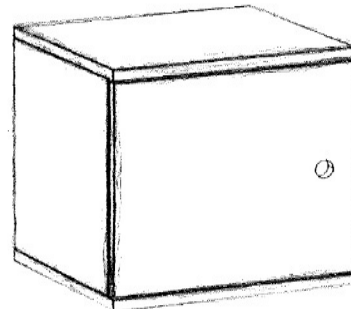
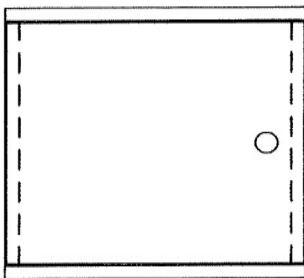

Modul SK2 Würfelmodul mit zwei Schubkästen

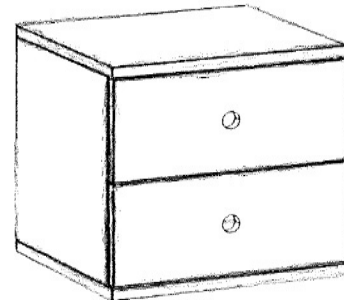
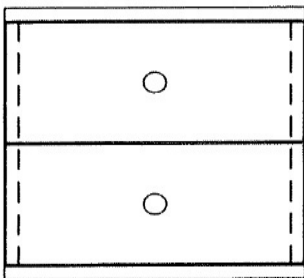

Modul SK3 Würfelmodul mit drei Schubkästen

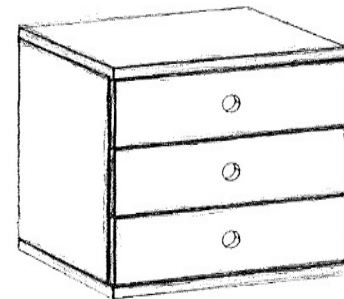
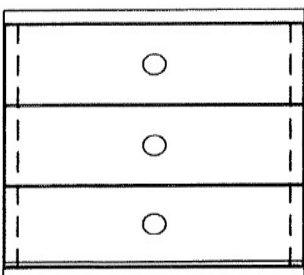

Anlage B – Würfelmodule in Plattenbauweise

Modul R

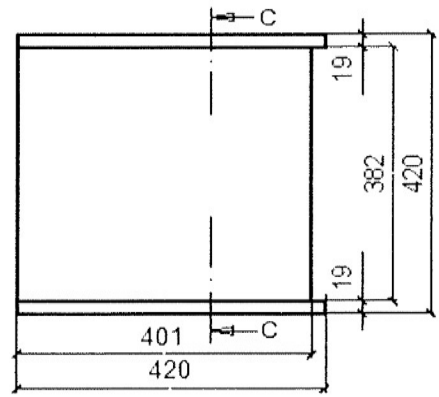
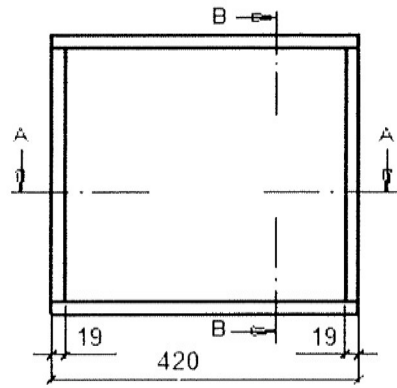

Modul T

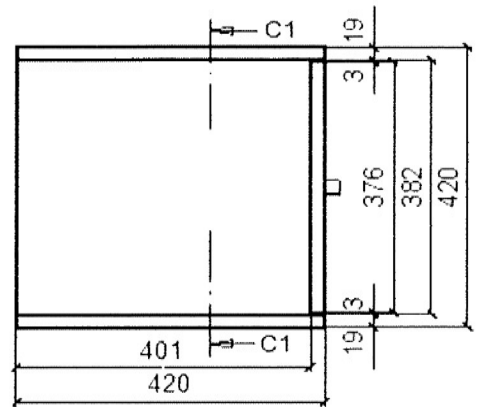
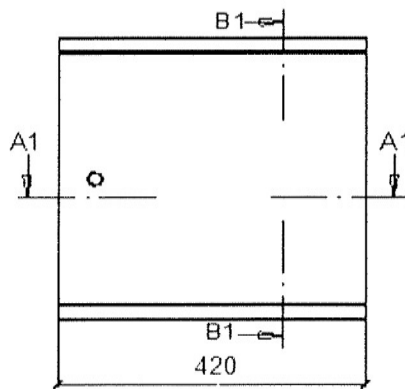

Modul SK2

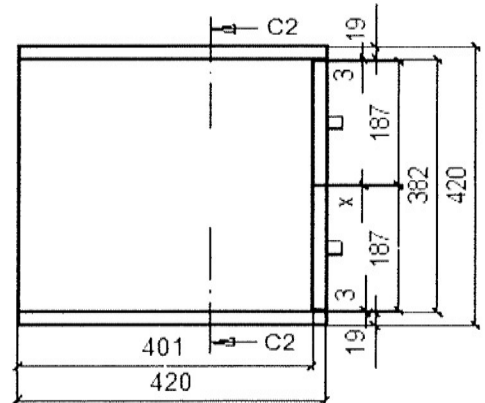
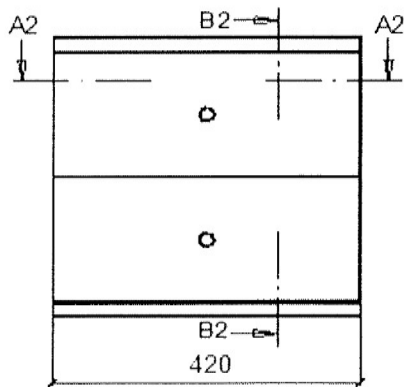

Modul SK3

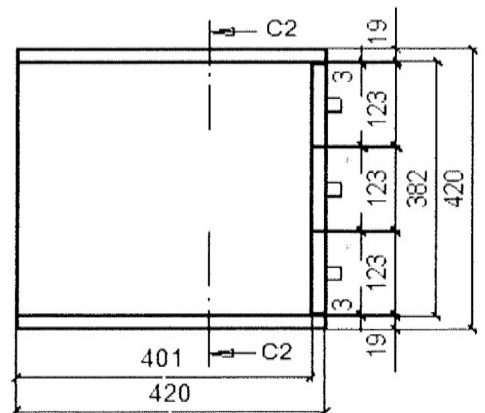
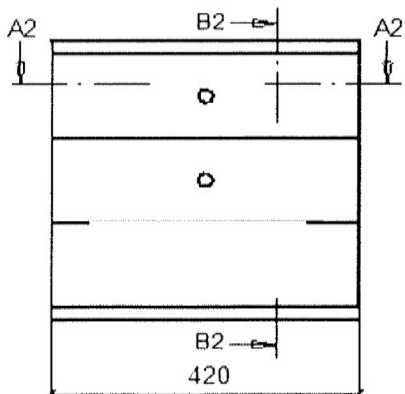

Anlage C: Würfelmodul T Schnitt A1-A1 (nicht maßstabsgetreu)

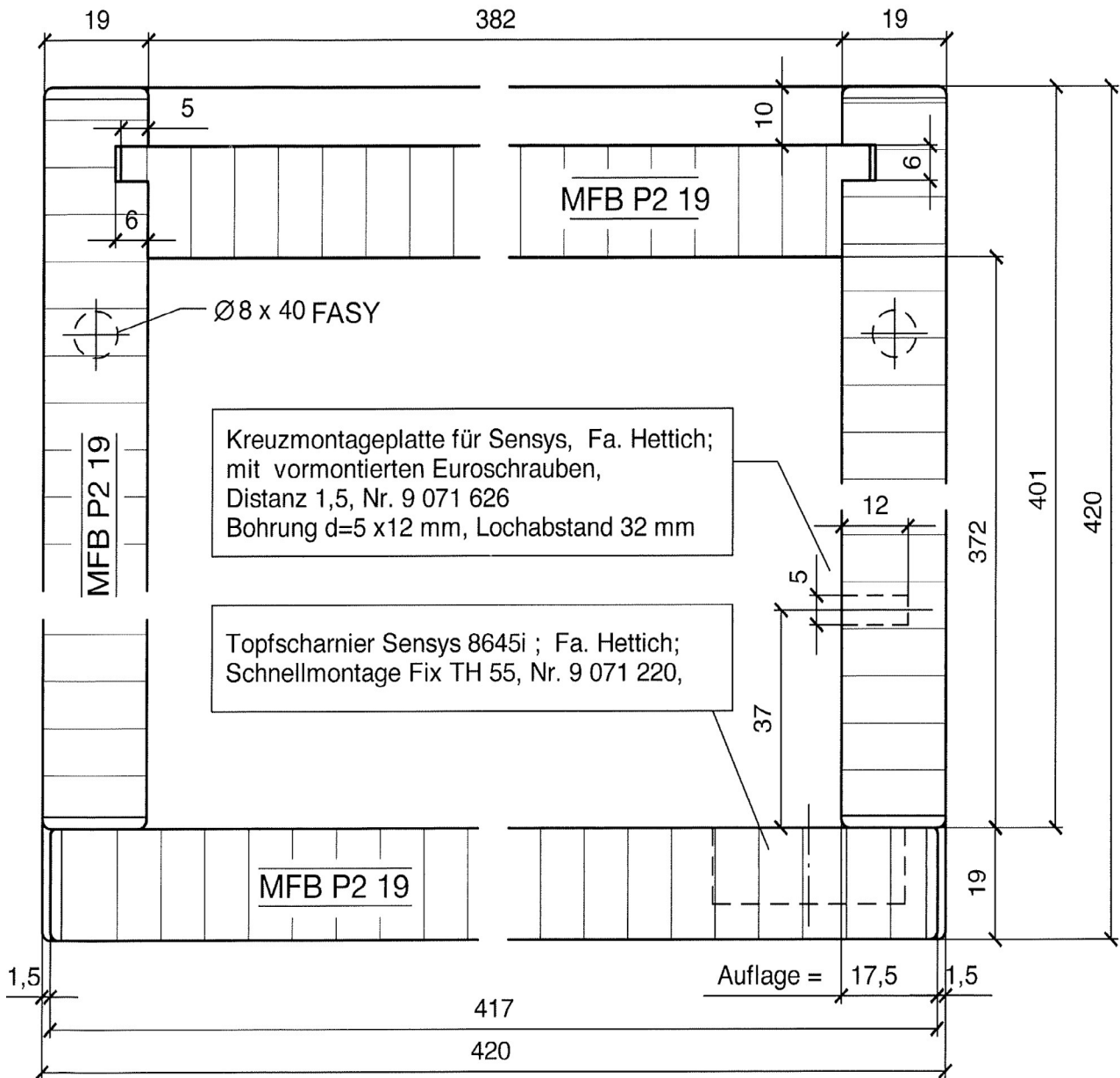

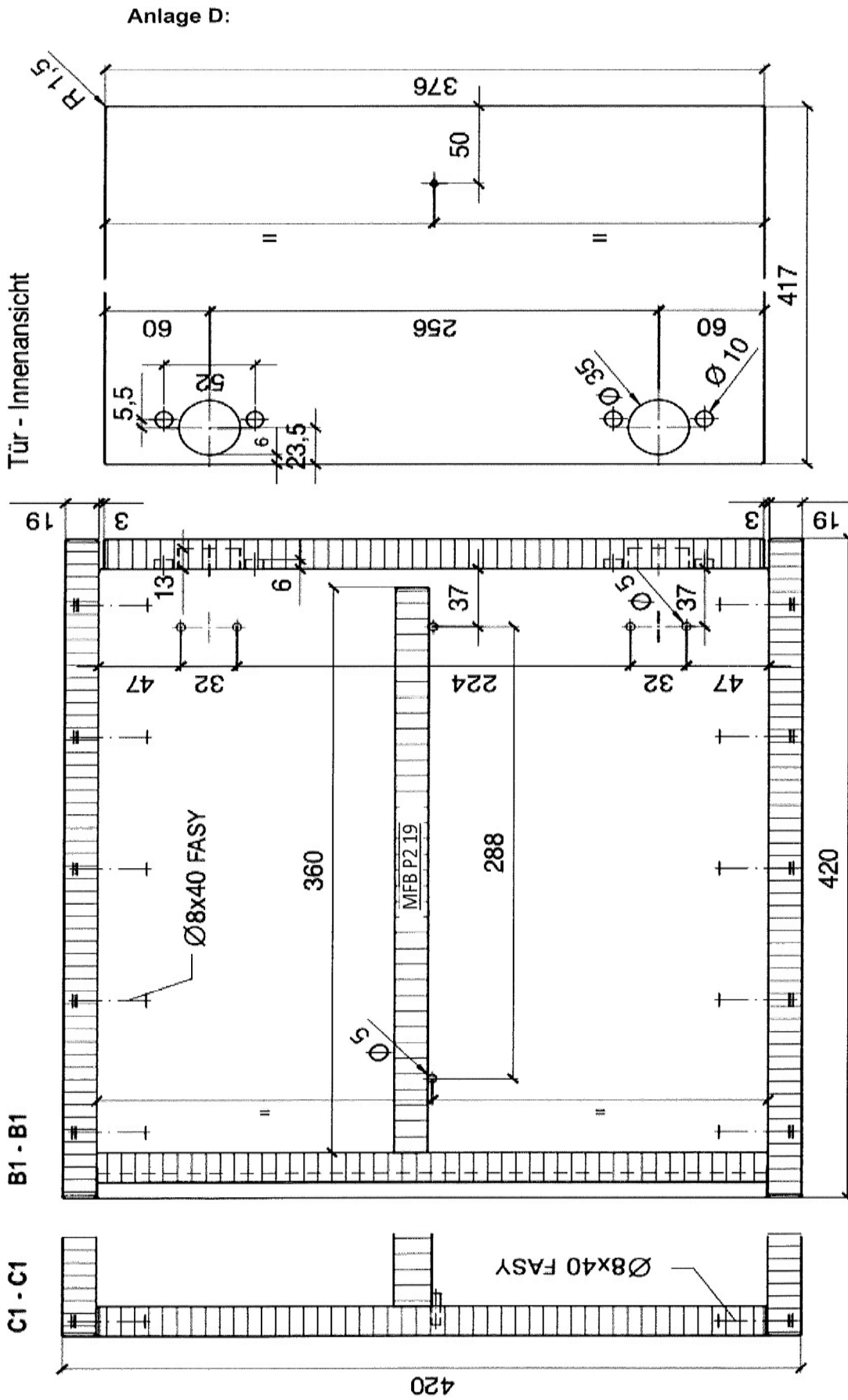

Anlage D: **Modul T mit Drehtür** Schnitte B1-B1 und C1-C1 (nicht maßstabgetreu)

Anlage E:

