

DT12**Betriebsanleitung beachten !**

- Kundenseitig
- Werkseitig
- Optional

Drehrichtungsumkehr:
Vertauschen von 2 Zuleitungen
(L1-L2)

**Follow the Operating Instructions !**

- By customer
- In factory
- Option

To reverse:
Interchange 2 supply leads (L1-L2)

**Voir prescriptions dans notice !**

- Côté client
- En usine
- Option

Inversion sens de rotation:
Permuter deux phases
d'alimentation (L1-L2)

Hohe Spannung, Y-Schaltung

Werkseitig geschaltet

High voltage, star-connection

Connected in factory

Haute tension, branchement Y

Câblée en usine

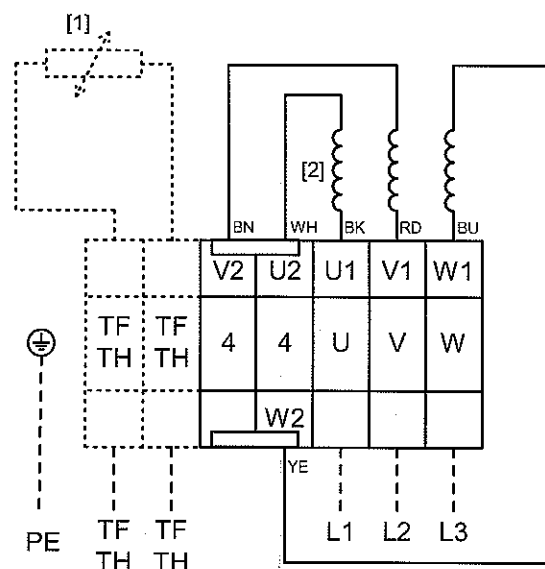

08 150 XX 06 01 00

- [1] **Option TF:**
Motorschutz mit Kaltleiter-Temperaturfühler TF
Option TH:
Motorschutz mit Bimetall-Temperaturwächter TH

- [2] Motorwicklung
[3] Doppeladerklemme verwenden!
Zubehörbeutel 0188 308 9

- [1] **Option TF:**
Motor protection with PTC thermistor sensors TF
Option TH:
Motor protection with bimetal thermostats TH

- [2] Motor winding
[3] Use twin wire terminals!
Accessory bag 0188 308 9

- [1] **Option TF:**
Protection du moteur par sondes thermométriques TF
Option TH:
Protection du moteur par contacts bilames TH

- [2] Bobinage moteur
[3] Utiliser les embouts doubles!
Sachet Accessoires 0188 308 9