

Guide to Flow Wrapping

www.boschpackaging.com

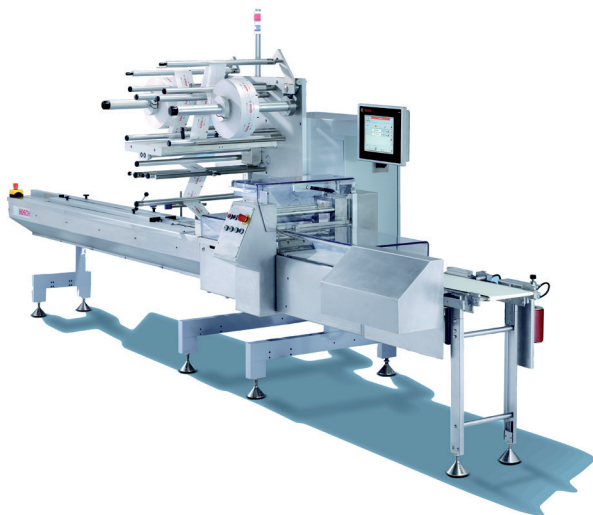

BOSCH
Invented for life



First Edition, 2011

This guide presents the basic principles of horizontal flow wrapping. It also includes common calculations and a troubleshooting guide to assist users in initially setting up their wrapper, changing over to new products, or solving problems common in flow wrapper operation.

Table of Contents

1. Flow Wrapping Principles.....	1-10
2. Sealing Fundamentals - Heat, Dwell Time, Pressure.....	11-13
3. Film Types.....	14-18
4. Common Calculations & Formulas.....	19-23
5. Flow Wrapper Troubleshooting.....	24-26

For additional support with your application, the Bosch Packaging Technology team is available. Please see the back cover for the contact information of the Bosch facility in your region.

Operation Overview

The drawing below shows a horizontal wrapper in motion:

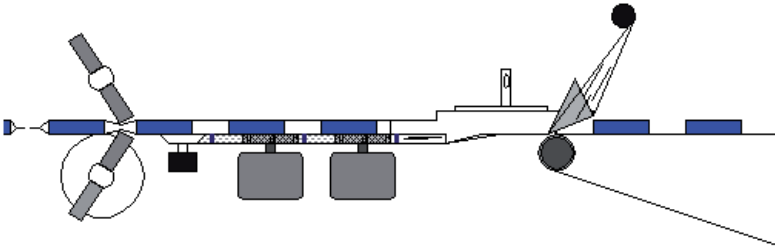

The wrapper packages product by wrapping it in film. The wrapper has an infeed conveyor, a film feed assembly, a forming area, a cutting head, and a discharge area. Product is placed on the infeed conveyor. As the infeed conveyor delivers product to the forming area, film is drawn from the film feed assembly into the forming area, where a film tube is formed around the product and a finseal is created. The film tube and the product then are delivered to the cutting head. The cutting head creates the endseals while it cuts apart adjoining wrapped products into individual packages, and delivers the packages to the discharge area. From the discharge area, the packages can be either cartoned at a packing station or accumulated for packing at a later time.

The wrapper has an infeed conveyor, a film feed assembly, a forming area, a cutting head and a discharge area.

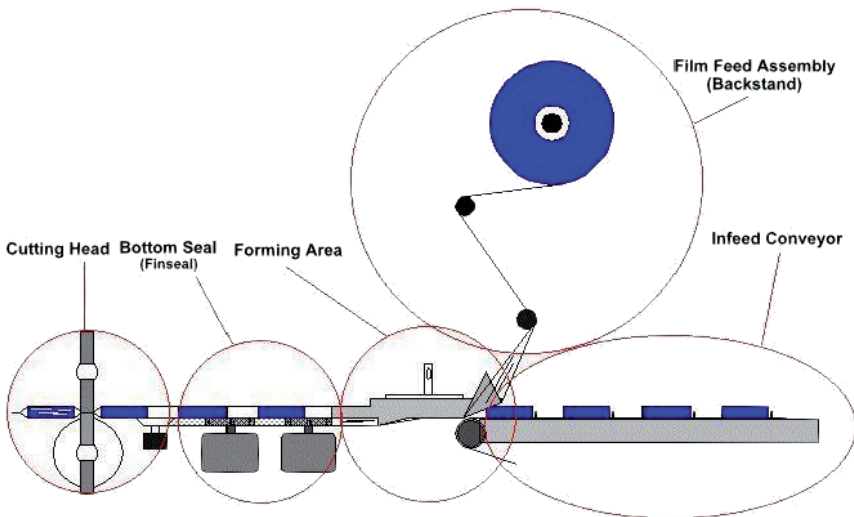

Infeed Conveyor

The infeed conveyor has a chain with lugs or pushers. The space between pushers is referred to as an infeed flight. Product is placed either manually or automatically onto the infeed conveyor where the pushers move the product through the wrapper for sealing. Whatever the style of wrapper, the Cutting Head and Infeed usually has a 1:1 ratio between them. (One Cut = One Flight Length) This ratio is necessary to keep product in time with the cutting head.

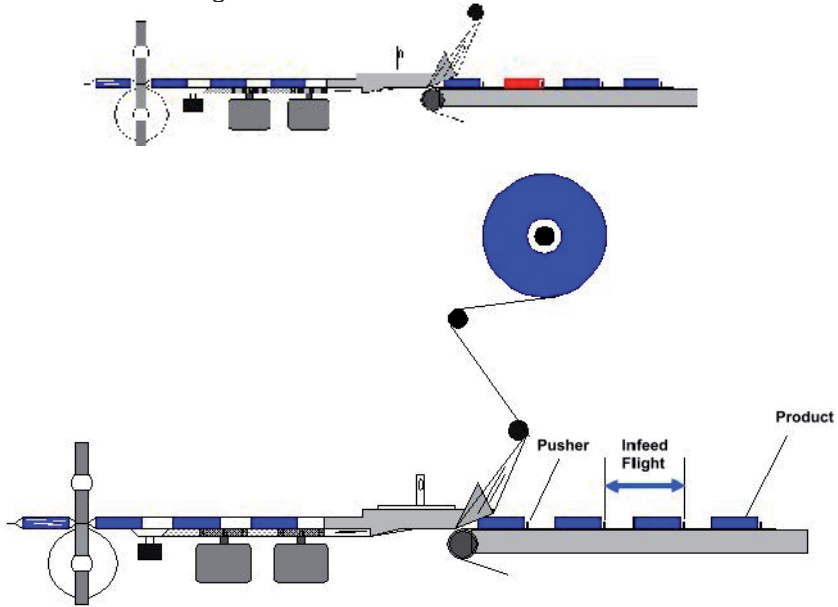

The dimensions of the pushers in the infeed chain are related to the product dimensions, particularly the height and the width of the product.

The height of the pushers must be adjusted to the height of the product. If the pusher is too high, it will run into the film at the transition point at the former. If it is too low, there is a risk that the product will rise over the top of the pusher. If there is a multi-layer package, the pusher must reach the top product otherwise the top product will not be transported.

The width of a pusher is determined by two characteristics:

- If there are two or more products side-by-side that need to be wrapped, then the pusher needs to be wide enough to securely push all the products.
- When the product is very vulnerable or soft, the impact and/or the pressure on the product needs to be limited, requiring the use of a wider pusher.

Feeding

Different types of product feeding can be distinguished: manual, semi-automatic or fully-automatic.

Manual feeding

The simplest way of feeding products into a flow wrapper is to put them manually in between the pushers of an infeed chain. Depending on the type of products and ease of operation, the maximum speed by which an operator is able to feed products into the infeed chain for a long period of time, is approx. 70-90 products per minute. Eye-hand coordination becomes an issue above that speed. Therefore, the maximum speed with manual feeding is not limited by the machine, but by the efficiency and speed of the operator(s).

Semi-automatic feeding

In semi-automatic feeding, products are taken manually from a main production line and subsequently entered into some type of automatic feeding system. From this feeding system the products are automatically transported in between the pushers of the infeed chain.

Semi-automatic systems can be a good alternative for those introducing new products into the market. The production volumes of these new products, in many cases, do not justify the investment in a fully-automatic wrapping line. A large part of the capital investment into a fully-automatic wrapping system lies with the Product Distribution System (PDS).

Fully-automatic feeding

In a fully-automatic feeding solution without manual interference, products are taken from the main production belt by a Product Distribution System(s) and automatically fed into the automatic infeed system of a flow wrapper.

In the majority of cases, a fully automatic wrapping system will be supplied with some kind of buffer or refeed system. The intention of these systems is that in the case of an unforeseen disturbance on the packaging line(s), the main production does not need to be stopped (for a limited amount of time). This is of great importance when stoppage of the production line(s) will have direct influence on the quality of the products (especially chocolate and baking lines).

Backstand

The backstand (also referred to as a film tower) consists of one or two spindles (also referred to as reel holders). There are restrictions to the maximum dimensions of the film reel. This can either be the maximum film width, the maximum outer diameter, or the weight of the film reel. This can be different for different types of machines.

For ease of operation, the backstand can be equipped with different options such as:

- **Converter splice detection:**
During the manufacturing process of film by film suppliers (converters), it is sometimes unavoidable that a single reel contains a splice to achieve the desired amount of film per reel. The film supplier will mark the position of these splices by adding tape. These are referred to as a converter splice. These markers can be detected by a photocell (converter splice detection) and then rejected on the discharge belt.
- **Powered film reels:**
Servo driven reel holders are necessary when film speeds exceed 70 meters per minute. Due to the big differences in speed (inertia) during splicing, ramp-up or ramp-down, of the active (running) reel of film and the new reel of film, extra drive of the new (heavy) film reel is needed to prevent rupturing the film.
- **End of reel detection:**
A function which detects the end of the film reel. This can be either a mechanical detection or detection via an inductive sensor.
- **Powered feed roll:**
Driven roller on the backstand that supports the transportation of the film and also contributes in creating a constant tension of the film with the former. This is necessary when:
 - film speeds exceeds 40 meters per minute
 - No Product No Bag function is present
 - wide film (\geq approx. 200 mm) is being used

- **Automatic film tracking:**
Both for looks and function, it is important that the center line of the film tracks in line with the center line of the machine. This tracking can be adjusted manually by turning a knob at the end of the reel holders which will cause the reel to go in or out. This adjustment can also be done automatically using two light diodes at the edge of the film reel with a fixed gap between them. During normal operation one of them should be covered. If both are covered, or open, the tracking of the film will be adjusted. This adjustment can be done by moving the reel holders in and/or out or by changing the angle of the (tracking) rollers in front of the former. The adjustment is within +/- 1 mm.
- **Splicer:**
A function which enables the automatic connection of two reels of film. It connects the end of the empty reel of film, to the beginning of the new reel, with manually placed double sided tape.
- **Film cutting device:**
Improves the efficiency of the splicer operation and reduces the number of rejected packages. Using an encoder, the remaining amount of film on the active film reel is monitored. Before the end of the film reel is reached, the film will be actively cut to create a well defined end of the film. Simultaneously, the splicing action is activated resulting in a controlled and defined splice. While this does improve the splicing efficiency, it has the disadvantage of wasting film as some film remains unused on the reel.
- **Self-centering film reel holders:**
This option eliminates mechanical adjustments by the operator to match the center line of the film reel to the center line of the machine when a new film reel is loaded. Self-centering film reels perform this automatically and are independent of the width of the film reel.

Transfer into Former

The pushers move the products in each flight forward into the former on the wrapper. If the flight length and the bag length are equal the speed of the product and film entering the former are the same. This condition will create the best possible transfer. The infeed flight can be slightly longer than the bag length but as a rule, never shorter than the bag length. Upon reaching the former, the infeed pusher drops down after placing the products into the former and onto the sealing material. The farther the product is pushed into the forming area before the pusher drops away, the better the transfer.

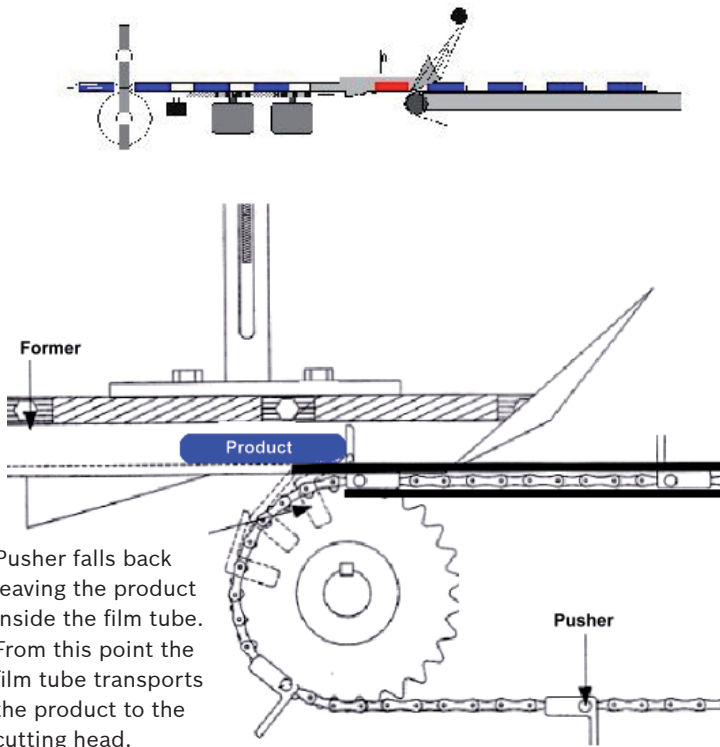

Former and Fin Wheels

As the products travel through the former, a layer of sealing material (film) is wrapped into a tube around the products with the two outside edges of the material mated together at the bottom. These two mating edges of sealing material then pass between a pair of rotating finseal wheels, which pull the film and product through the former and seal it together with heat and pressure. If running cold seal material, no heat is required. There is a small amount of tension on the film that is required to properly track film into the former area.

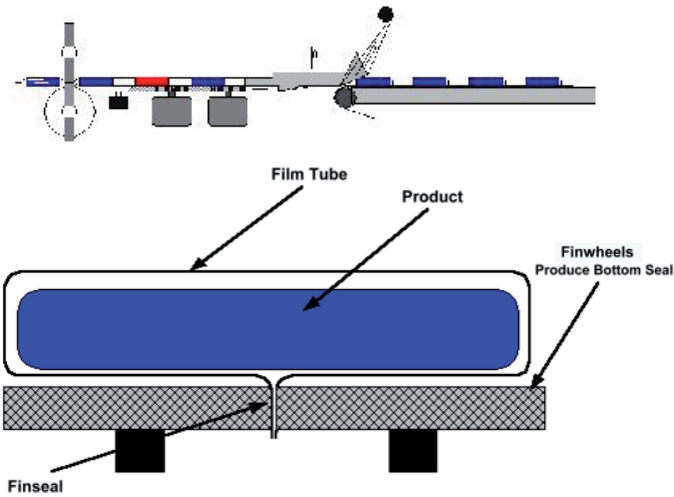

The sealed fin strip is folded over against the package by the auxiliary fin wheels. In some cases the machine does not have auxiliary fin wheels. In that case the machine would have a stationary fold over lip to fold the finseal over before entering the Cutting Head area.

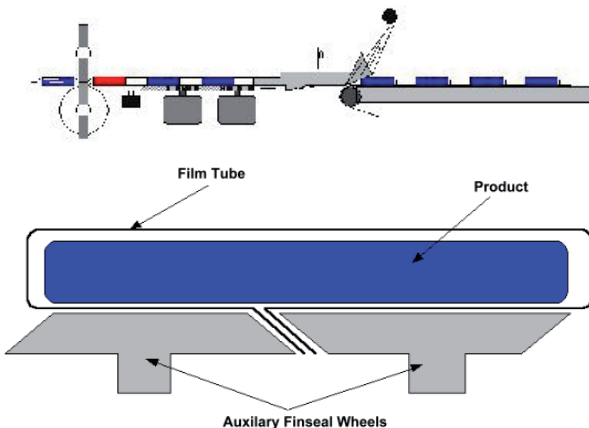

Endseal Crimpers

The endseal consists of a pair of rotating shafts each equipped with 1 to 4 crimpers. Each upper crimper has a knife and each lower crimper an anvil. As the shafts rotate they seal the front of one package, the back of another, and cut the two products apart in one motion. The knife can be either straight or serrated for an easy open feature.

When the material is sealed, the knife and anvil cut the material in the center of the seal to create a completely sealed individual package. The sealed packages are then removed from the endseal area by the discharge conveyor belt. From here the sealed packages are cartoned or conveyed for further handling.

The speed of the discharge conveyor determines the amount of spacing between the products and is usually adjustable.

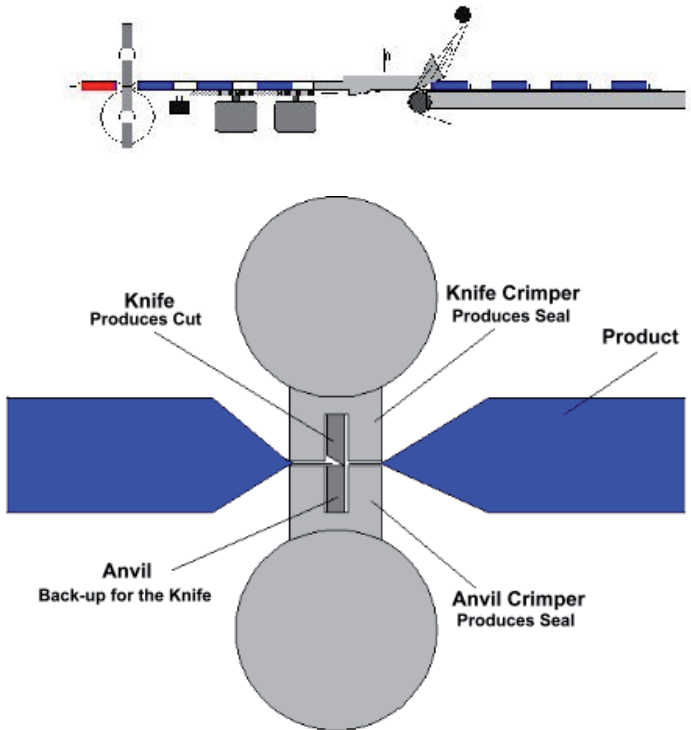

Cutting Head Configurations

The objective with the multiple crimper configurations as shown is to match the number of crimpers to the cut-off length to achieve a smooth constant motion in the crimper shaft. The illustration refers to the common terminology used for the different cutting head configurations.

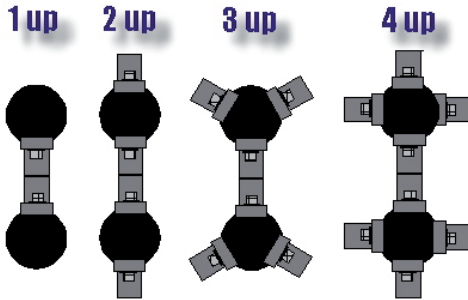

Rotary head:

The standard movement of a horizontal flow wrapper cutting head is a rotary movement. A rotary movement (with multiple jaws) is a balanced movement, which enables high running speeds. A rotary cutting head can be equipped with several numbers of jaws. The jaws have a rounded profile which results in a single point of contact with the film when running. When speed fluctuations are minimal and the temperature is within the optimal sealing window of the film, the packages will be airtight.

Due to the relatively simple construction, it is the most economical execution of a cutting head.

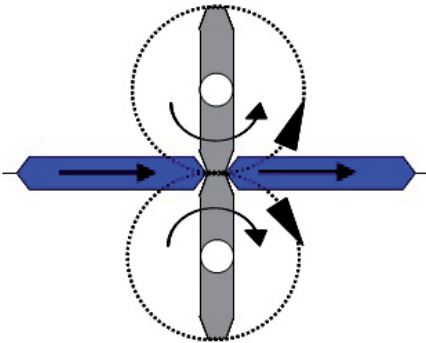

As a rule of thumb, the maximum capacity per jaw for a rotary cutting head can be assumed to be approx 150 packages per minute.

Long Dwell head:

One of the possibilities to improve sealing capability is to extend the time by which the heated jaw is in contact with the film. This means that the jaw is running with the film, with identical speed. This is referred to as extended or long dwell time. The main purpose therefore of a Long Dwell Head is to improve the sealing capabilities of a specific quality film.

D-Cam Profile:

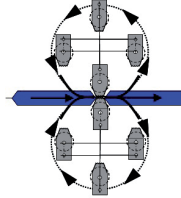

In comparison to a rotary head, the usage of a D-Cam motion profile will result in increasing the maximum film sealing range by 15-20%. Typically, this type of jaw movement is not used to guarantee an air tight package, but to enhance the maximum capacity (film speed) of a specific quality film. The D-Cam profile heads are typically equipped with either 1-up to 2-up head configuration depending on product dimensions and required capacity. A D-Cam long dwell has a fixed amount of crimper separation and dwell distance. This design has a smaller “Foot Print” than a box motion and can be less expensive.

Box Motion Profile

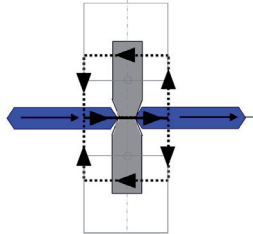

Similar to the D-Cam, the Box Motion Profile is designed to extend the time by which the jaws are in contact with the film, so it can transfer more heat into the film as opposed to increasing temperature which can potentially melt the film. In comparison to a D-Cam, the usage of a Box Motion profile may result in increasing the maximum film sealing range by another 15-20%. The main purpose of using a Box-Motion type cutting head is to guarantee air tight packages. Therefore, this type of jaw movement is used for heavy, thick films (often metalized) and required for pharmaceutical products. A Box-Motion type cutting head is always equipped as a 1-up configuration. The maximum capacity is dependant on the required cut-off length. The Box Motion profile uses separate actuators (servo or pneumatic) for the horizontal and vertical motions allowing a variable amount of crimper separation and dwell distance to be achieved. This design typically requires a larger machine “Foot Print” than the D-Cam and can be more expensive.

General Sealing Information

Generally speaking, two types of film can be distinguished; heat seal film and cold seal film. Choices with respect to the use of heat or cold seal film depends on a variety variables, such as:

- product characteristics
- material costs
- required capacity/speed
- necessary barriers (Ultraviolet, Oxygen, etc.)
- hermetic seal strength or integrity

Cold Seal Films

Cold seal films consists of a base material (carrier) and a thin layer of glue. The sealing of this type of film is achieved by pressing the two layers of glue together. Therefore, a welding process does not take place and as a result, cold seal film can never offer the same protection and hermetic seal qualities as heat seal film. A further disadvantage of cold seal film is the fact that it needs to be stored in a climate controlled room otherwise the quality of the glue may be negatively affected. The cost for cold seal film is generally higher than heat seal film. However in theory, cold seal film can be used at high film speeds and may be beneficial when dealing with temperature sensitive products, such as chocolate.

Heat Seal Films

When high integrity seals are required, heat seal film offers the best alternative. The remainder of this section will discuss sealing of heat seal films since this type of film is more common.

One of the most important functions of the sealing material is its ability to produce an adequate heat seal over a wide temperature range. Regardless of what the sealing material looks like, (clear or cloudy) or how good the flat sheet moisture barrier properties, the sealing material is not functional on a horizontal wrapper if it does not have a reasonable operating range. If the sealing material seals poorly, or if its sealing range is so narrow that complete seal continuity cannot be maintained, packaging efficiencies and seal integrity will suffer.

A sealing material with good moisture and flavor barrier properties can lose out to sealing materials with less protective qualities if it has poor seal continuity.

To produce optimum seals on a horizontal wrapper, a few adjustments may be required from time to time. A need for making these adjustments can be created by many variables. Some of these are: worn sealing jaws, fluctuation in electrical line voltage, change or variation in sealing material and also speed changes in the equipment. In many cases more than one product and sealing material are used on a single wrapper which necessitates making adjustments.

In order to correctly make the temperature adjustment to compensate for a change or degradation of seal quality, it is important to know what is required to produce a seal on a thermoplastic coated material.

Sealing Information

To produce a seal, there are three important factors which must be kept in mind and controlled. These are HEAT, DWELL and PRESSURE. The preciseness in which these three factors are controlled and balanced, will determine to a great extent the quality of the seals.

Heat

Temperature of the sealing surfaces (heat is not necessary with cold seal film).

Dwell

Amount of time the heated surfaces are in contact with the sealing material

Pressure

Amount of pressure applied to the sealing material when the heated surfaces are in contact with the material

Heat - Dwell - Pressure

Whenever a change is made in any one of these factors, one or both of the other two factors must be adjusted to compensate for this change.

EXAMPLE: If the speed of the wrapper is increased, the dwell time in which the heated surfaces are in contact with the sealing material is reduced. If this change in speed is significant, the sealing temperature may need to be increased. Leaving the temperature at too low a level will result in poor seals due to insufficient heating of the material. If on the other hand the wrapper speed is decreased, the dwell time will be increased. If this change is significant, the sealing temperature should be lowered. Leaving the temperature at too high a level while operating at a reduced speed will over-soften the coating, sometimes creating blisters in the coating that may cause a buildup of coating on the sealing surfaces. This can result in the sealing material sticking to the sealing surfaces, which may cause the new seals to be pulled open or weakened as the package moves forward.

Temperature

Excessive temperatures will create as much problem in producing a continuous heat seal as too little heat.

A rule of thumb for setting the temperature on a wrapper running clear sealing material is as follows. Slowly increase the sealing temperature until the seal area starts showing a milky white appearance, then in 5 degree to 10 degree increments, reduce the temperature until the seal area is clear.

On other types of material, slowly increase the temperature until the seal is correct. As long as the wrapper is held at a constant speed and the sealing temperature is controlled properly, seals should be good. Since the HEAT, DWELL and PRESSURE on each wrapper is unique there are no hard and fast recommended seal settings. Each wrapper must be adjusted according to its individual characteristics.

Horizontal Form Fill and Seal Film Structures

- **Polypropylene (PP – OPP) Film**

Polypropylene is the most commonly used film for horizontal form fill and seal. It is used to over wrap snack foods, candy, baked goods, etc. The common make-up of this film consists of an outer layer, a polypropylene core and a sealant layer on the interior. The outer layer is commonly Acrylic coated to prevent the film from melting on the crimping jaws and also to reduce friction on contacted surfaces.

Polypropylene film over wrap provides a containment seal and protection from dirt and dust. It also provides some degree of protection from moisture and oxygen, but over time this film does allow air exchange from inside to outside.

Polypropylene film can come in literally hundreds of laminations depending on your specific needs. Unprinted polypropylene is a clear film that provides complete visibility of the product inside.

Polypropylene film can be supplied with several types of heat seal layers or with a cold seal adhesive layer. Sealant layers such as metallocene, surlyn or EVA, melt at lower temperatures than most sealant layers and tend to increase line speeds.

Polypropylene films can be laminated with other materials such as low density polyethylene and used for Modified Atmosphere Packaging (MAP) or gas flush applications. These gas flush applications require a barrier film and “hermetic” seals. Barrier films will not allow for exchange of atmosphere from the inside of the package to the outside or vice versa. In modified atmosphere packaging the oxygen inside the package is replaced with nitrogen, carbon dioxide or a blend of both gases. This inhibits the growth of mold and extends the shelf life of the product inside the package.

- **Polypropylene (PP – OPP) Film**

Polypropylene film is also available in an opaque film. This film provides a nice white appearance and also provides for very attractive graphics when printed. This film is commonly used for chocolate bars and ice cream treat over wraps. This film can also be either heat sealable or cold seal. The white layer helps to slow product deterioration due to light sources.

A third type of polypropylene film is metalized. This film has a vacuum deposited aluminum layer applied when the film is produced. The metallization of film enhances the film's ability to protect the product from outside oxygen and moisture. It also provides some degree of protection from light deterioration of the product. Metalized opp is used for candy bars, breakfast bars and in some applications pharmaceutical applications where it replaces foil laminates.

Most polypropylene films run in a temperature range of 225F – 425F, depending on thickness of film, sealants, coatings and speed.

- **Polyester (PET) Film**

Polyester films are commonly used as an outer layer in laminations with other materials. Polyester has good heat resistance which performs well in high speed applications. This film will not shrink due to high temperatures like polypropylene will. The polyester layer in a laminate also adds some strength to the film structure.

Light gauged polyester has become the standard over wrap material for toaster pastries. Because of its heat resistance, polyester wrapped products can be heated in microwaves. There is also a variety of polyester that can be used in ovens. This material is used to wrap products such as French bread. It is also used for lidding material on most frozen trayed products. These products can go directly from freezer to oven!

48 gauge polyester along with a sealant layer of LDPE is widely used for moist towelettes and baby wipes. Polyester films will typically accept temperature settings as high as 500F +.

- **Polyethylene (PE) Film**

Polyethylene film comes in three common versions:

1. Low Density Polyethylene (LDPE) commonly used in shrink applications such as pizzas, soap bars for South America and a variety of other shrink bundle applications.

LDPE can also run on a fin seal type horizontal wrapper if the film is produced with a sealant layer on the inside. Typically EVA is used for a sealant layer. This film is primarily used for wrapping plastic cutlery, syringes for the pharmaceutical industry and literature over wrap. Sealing temperatures for LDPE with an inside sealant layer are usually in the 225F – 250F range.

2. Linear Low Density Polyethylene (LLDPE) is used in laminations of materials to add tear resistant properties to the finished film structure. It can also be used as a sealant layer in laminated films.

3. High Density Polyethylene (HDPE) requires a sealant layer in order to seal on a fin seal type horizontal wrapper. It is used as an outer layer along with LDPE and an EVA sealant layer for wrapping waffles, crackers and plastic cutlery, to name a few applications. Sealing temperatures for HDPE blends are typically in the 250F - 300F range.

- **Foil Laminations**

Foil laminations are made up of an aluminum alloy sheet sandwiched between another film layer and an inside sealant layer. These laminations can be several layers thick depending on the desired film properties. Thickness of the foil layer can also vary widely.

Foil laminations are used for pharmaceutical products and light sensitive products. The outer layer of a foil lamination may be paper, polyester, nylon and polypropylene or others.

Foil laminates have the highest barrier properties of any material used for over wrap. Seal temperature for foil laminations can range from 300F - 500F depending on thickness, outer layer and sealant layer.

Foil laminations often require extended dwell wrappers to seal properly.

- **Paper/polyethylene laminations**

Paper/poly laminations are commonly used to wrap gauze bandages. Several frozen food products such as pot pies and burritos are wrapped in paper/poly films. Some manufacturers have added a thin metalized layer to the film; this is called “suseptor” film. The suseptor layer works in the microwave to help brown or promote crispness of the product. Paper/poly films typically do not run at high rates of speed due to the insulating factor that the paper creates. Typical heat ranges are 350F – 500F and may require preheat in order to attain line speeds required.

- **Glassine Film**

Glassine is a grease resistant paper with an inner sealant layer. It is typically use for fried products such as fruit pies found in vending machines. This type of film is being phased out in favor of other materials that run faster and are not prone to tearing.

- **Valeron Film**

This is a name that has been given to a film that was developed for its superior tear strength properties. It is used for wrapping most chlorine tablets for toilet tank and swimming pool use. This film provides an excellent moisture barrier, but its highest asset is its very high resistance to punctures and tears. These qualities make it child resistant which is a requirement for commercial chlorine products. This film typically will not seal at speeds above 450 inches per minute. The film also has a very narrow sealing window. This means the temperature window between good seals and melting the film is very small!

- **Shrink Film**

There are several films that fall into the shrink film category and include films made from polyethylene. Low density polyethylene and linear low density polyethylene films are common along with some polypropylenes. Shrink films can also be made from an ethylene-propylene copolymer and multi-layer polyolefin. These films are always run on a wrapper using a bottom lap seal and a hot knife end seal.

Product wrapped using shrink films are: compact disks, candles, greeting cards, box over wrap and trays of frozen product.

Also included in the shrink film category is Polyvinyl Chloride (PVC). PVC is used because of its high clarity and stiffness. It is used in place of polyolefin film where very high clarity is desired.

PVC films are run using a lap seal that is usually a static seal. The end seal is created by a special PVC knife that seals and separates the packages. These films are also used to wrap candles, greeting cards and compact disks.

Cutting Head Diameter

The graphic below indicates how to determine your Cutting Head Diameter and maximum product height.

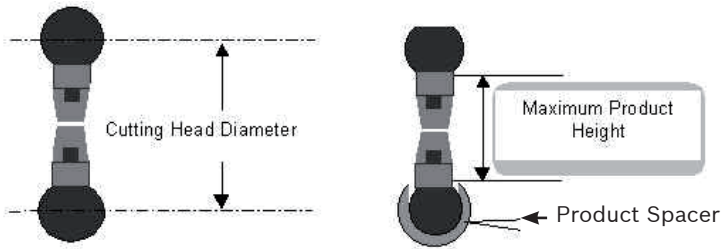

Correct head diameter is required to have proper clearance as the product passes through the cutting head. Having the correct cutting head diameter for your cutoff will result in less speed change or pause and a more constant velocity in cutting head.

The charts on the next pages are designed to give you information about minimum cutoffs, maximum cutoffs, and maximum product heights. Information needed to determine parameters such as head size and number of crimpers per shaft.

Product Spacer Formula is:

$$\text{Head Diameter} - \text{Product Height} = \text{Product Spacer Diameter}$$

Product Spacer Diameter x 3.14 has to be at cutoff length or greater than cutoff length.

Head Diameters and Cutoffs

Correct head diameter is required to have proper clearance as the product passes through the cutting head. Having the correct cutting head diameter for your cutoff will result in less speed change or pause and a more constant velocity in cutting head.

The charts below are designed to give you information about minimum cutoffs, maximum cutoffs, and maximum product heights. Information needed to determine parameters is head size and number of crimpers per shaft.

Note: Maximum and minimum cutoffs are approximate only. Actual testing with the machine at speed is required to achieve exact maximum and minimum cutoffs.

Head Diameter	Crimpers per Shaft	Minimum Cutoff	Maximum Cutoff	Maximum Product Height
100mm (3.94")	1-up	140mm / 5.51"	315mm / 12.4"	40mm / 1.57"
	2-up	85mm / 3.35"	155mm / 6.1"	40mm / 1.57"
	3-up	55mm / 2.17"	105mm / 4.13"	20mm / 0.79"
120mm (4.72")	1-up	170mm / 6.69"	375mm / 14.76"	60mm / 2.36"
	2-up	90mm / 3.54"	185mm / 7.28"	60mm / 2.36"
	3-up	65mm / 2.56"	125mm / 4.92"	30mm / 1.18"
150mm (5.91")	1-up	200mm / 7.87"	470mm / 18.5"	90mm / 3.54"
	2-up	110mm / 4.33"	235mm / 9.25"	90mm / 3.54"
	3-up	80mm / 3.15"	150mm / 5.91"	45mm / 1.77"
180mm (7.09")	1-up	250mm / 9.84"	565mm / 22.24"	110mm / 4.33"
	2-up	130mm / 5.12"	280mm / 11.02"	110mm / 4.33"
	3-up	95mm / 3.74"	180mm / 7.09"	60mm / 2.36"

Determining Cutoff Length

The Formula for determining cutoff length is:

$$\text{Product Height divided by } 0.86603 + \text{Total Crimper Width} + \text{Total Product Length.}$$

This formula is a starting point only. Testing on your machine with actual product and film is necessary to determine film cutoff.

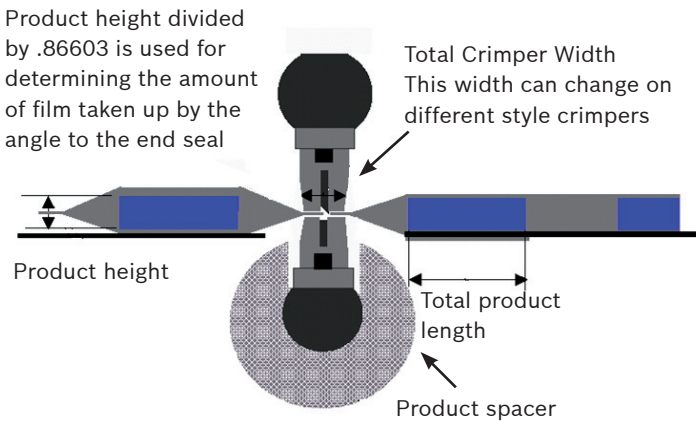

Determining Web Width

The formula for sizing the film web width is:

$$2 \times (\text{Product Width} + \text{Product Height} + \text{Fin Seal Roller Height} + 5\text{mm})$$

The 5mm (0.2”) can be explained by the distance (including the height and thickness of the deckplates) from the product to the fin sealing roller and some extra film to assure good tracking in the finseal rollers.

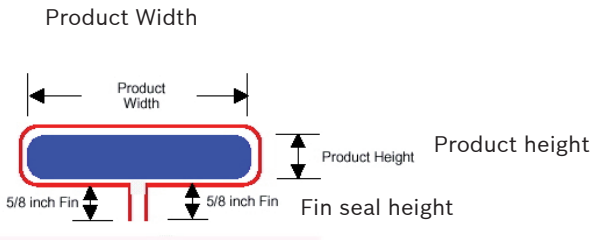

Common fin sealing roller heights are: 6, 9 and 15 millimeter. Together with the 5mm of film for tracking purposes, this results in finseal widths of 11, 14 and 20 millimeters respectively.

This calculation can be used for most products with a consistent dimension. For products with more variable dimensions, such as bakery products, the film width must be increased to allow for bigger variations. This however, creates looser packs with wider finseal areas.

The sizing and formula recommendations are used for hard film wrappers. Use these formulas for a starting point only. Testing on your machine with actual product and film is necessary to determine film sizing and cutoff.

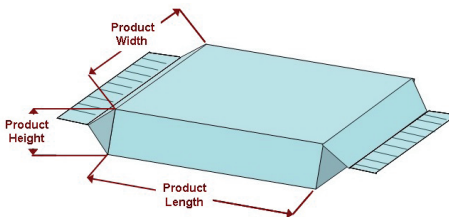

Former Sizing to Product

When dealing with products that are not stable in size, you must base your former sizing on the cross section of largest product.

Typical spacing for unstable products is ¼ inch clearance around the entire product and the inside of the former.

Typical spacing for stable products is 1/8 inch clearance around the entire product and the inside of the former.

When using product guides that enter the former you need to allow for the thickness of the guides.

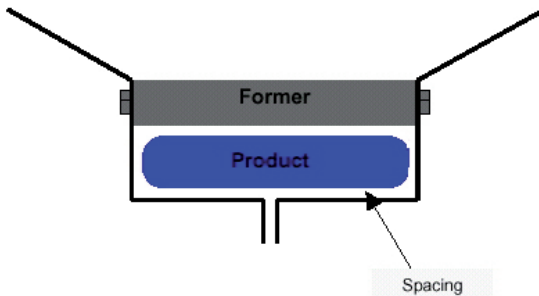

The sizing and formula recommendations are used for hard film wrappers. Use these formulas for a starting point only. Testing on your machine with actual product and film is necessary to determine film sizing and cut off.

Film Sizing to Former

To determine film width for a former use:

$2x$ inside height + $2x$ inside width + $1\frac{1}{4}$ inch for the fin seal.

In some cases the film width may vary from $1\frac{1}{2}$ to 2" and may work. Actual testing in production environment would be required.

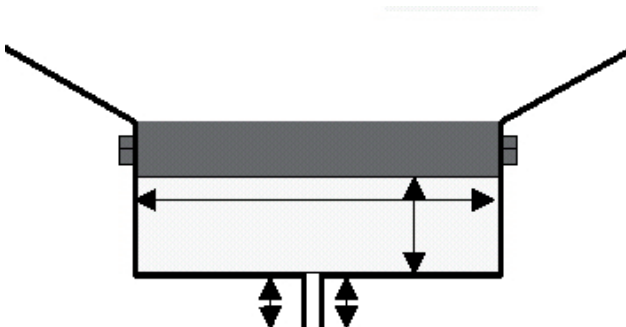

Flow Wrapper Troubleshooting

Problem: Product jams in the forming area and/ or cutting head.	
Possible Cause	Solution
The product is moving slower than the film - the infeed pitch is much shorter than the product length	Enter the correct infeed pitch and package length values

Problem: The product is not placed consistently inside the package - it wanders or drifts inside the package.	
Possible Cause	Solution
The film is moving faster than the product when they enter the former - the infeed pitch is shorter than the package length	Enter a larger infeed pitch value and/ or a smaller package length value

Problem: The film wanders across the pivot arm rollers and the packages are wrapped incorrectly.	
Possible Cause	Solution
The film is not wrapped at least 180° around the first pivot arm roller	Reposition the pivot arm rollers and/ or the pivot arm

Problem: The film does not feed properly.	
Possible Cause	Solution
The film is not threaded correctly	Check the film threading
The finwheels are open	Move the finwheel lever to the closed position
The finwheels are not pressed together tight enough	Increase the pressure between the finwheels

Problem: The serrations on the finwheels are cutting through the film.	
Possible Cause	Solution
The finwheels are pressed together too tight	Decrease the pressure between the finwheels

Problem: The serrations on the crimpers are cutting through the film.	
Possible Cause	Solution
There is not enough clearance between the crimpers	Increase the clearance between the crimpers
The crimper sealing pressure is too high	Decrease the crimper sealing pressure

Flow Wrapper Troubleshooting

Problem: The finseal is not holding together.	
Possible Cause	Solution
The finwheel temperature setting is too low	Increase the finwheel temperature setting
The finwheels are dirty	Clean the finwheels
The finwheels are not pressed together tight enough	Increase the pressure between the finwheels
The film is too narrow	Load a wider film roll

Problem: The endseals are not holding together.	
Possible Cause	Solution
The crimper temperature setting is too low	Increase the crimper temperature setting
The crimpers are dirty	Clean the crimpers
There is too much clearance between the crimpers	Decrease the clearance between the crimpers
The crimper sealing pressure is too low	Increase the crimper sealing pressure

Problem: The film is being wrinkled.	
Possible Cause	Solution
The wrong product spacer has been installed	Install the correct product spacer
The product spacer is not set at the correct height	Adjust the height of the product spacer
The film tension is not adjusted properly	Adjust the spring tension
The film is not centered over the former	Center the film roll on the parent roll

Problem: The finseals are bubbly and/ or melted.	
Possible Cause	Solution
The finwheel temperature setting is too high	Lower the finwheel temperature setting
The finwheels are dirty	Clean the finwheels

Problem: The endseals are bubbly and/ or melted.	
Possible Cause	Solution
The crimper temperature setting is too high	Lower the crimper temperature setting
The crimpers are dirty	Clean the crimpers

Problem: The film is blurred or discolored at the edge of the finseal.	
Possible Cause	Solution
The finwheel temperature setting is too high	Lower the crimper temperature setting
The crimpers are dirty	Clean the crimpers

Flow Wrapper Troubleshooting

Problem: There are "chicken tracks" in the finseal.	
Possible Cause	Solution
The finwheels are dirty	Clean the finwheels
The finwheel temperature is too hot	Lower the finwheel temperature setting
The festoon roller's brake is not releasing properly	Check that the festoon roller's brake is releasing properly. If it is not releasing properly, call manufacturer for further assistance

Problem: The film comes out from between the finwheels.	
Possible Cause	Solution
The finwheels are open	Move the finwheel release lever to the closed position
The film is too narrow	Load a wider film roll

Problem: The finseal is too deep.	
Possible Cause	Solution
The film is too wide	Load a narrower film roll

Problem: The finseal is twisted.	
Possible Cause	Solution
The film is too wide	Load a narrower film roll

Problem: The blouse of the package is too loose.	
Possible Cause	Solution
The pivot arm is too high	Lower the pivot arm

Problem: The blouse of the package is too tight.	
Possible Cause	Solution
The pivot arm is too low	Raise the pivot arm

Problem: The crimps in the endseals are misaligned.	
Possible Cause	Solution
The crimpers are not aligned properly	Adjust the alignment of the crimpers

Notes

Bosch Packaging Machines Horizontal Flow Wrapper Centers of Excellence

North America

Bosch Packaging
Technology, Inc.
869 South Knowles Avenue
New Richmond, WI 54017
USA
Tel: 715 246-6511
sales.packaging-nrd@
bosch.com

South America

Robert Bosch Tecnologia
de Embalagem Ltda.
Av. Jurua, 606, Alphaville-
Brazil
06455-010 Barueri SP
Tel: +55 11 2117 6800
pabr@bosch.com

Europe/ Africa

Bosch Packaging
Technology BV
Conradstraat 4
Netherlands-3100 AA
Schiedam
Tel: +31 10 4885899
info.packaging-sdm@
bosch.com

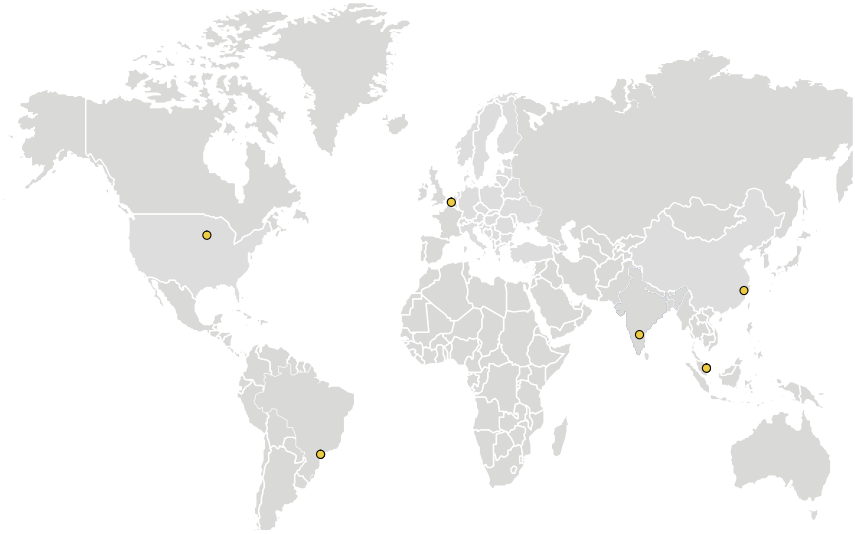

Asia

Bosch Packaging
Technology
(Hangzhou Co. Ltd.)
680, Rd No 23
310018 Hangzhou
P.R. China
Tel: +86 571 8726 5000
saleschina@boschpackaging.
com

Bosch Packaging
Technology
(Singapore) Pte Ltd
7 Tai Seng Drive, #05-02
Singapore 535218
Tel: + 65 6380 8319
enquiry.packaging-sg
@bosch.com

Bosch Limited
Packaging Technology
Division
N4, Phase IV, Verna
Industrial Estate
Verna, Goa 403722 India
Tel: + 91 832 6692017
boschpackaging@
in.bosch.com

The information contained herein is based on our testing and experience and is offered for the users consideration, investigation and verification. Since operating and use conditions vary and since we do not control such conditions, we must **DISCLAIM ANY WARRANTY, EXPRESSED or IMPLIED**, with regard to results obtained from the use of this product.